

# HB090A Series

## Ordering Informations

Model no.	Color	Size	Light Source	Luminous Intensity
HB090AWW01	Warm White (3,000-3,500K)	Ø415 x 612mm	90W	8500-9000Lm
HB090ANW01	Neutral White (4,500-4,750K)	Ø415 x 612mm	90W	9000-9500Lm
HB090AWE01	Cool White (5,500-6,500K)	Ø415 x 612mm	90W	9000-9500Lm



HB090A Series

## Outline Drawing

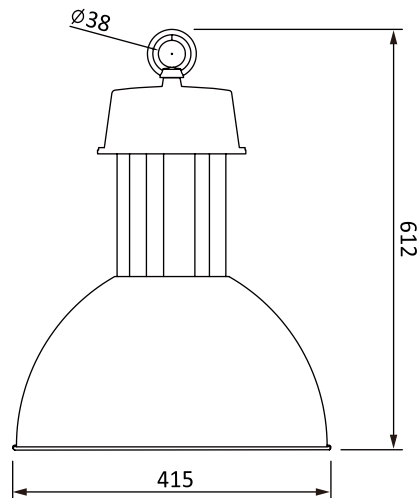

\* The dimensional outline drawings are common in (HB090AWW01, HB090ANW01 and HB090AWE01)

Unit: mm

## Features

- Aluminum casing with special extrusions design
- Energy saving
- Eco-friendly product
- Long life time
- High luminance
- Low power consumption
- High efficient heat release mechanism
- Low surface heat against hand touch
- No UV or IR damage light sensitive items

## Specifications

Parameter	Rating value
Power Consumption	90W
Input Voltage	AC 110-260V, 50/60Hz
Light Source	90W power LED
Operating Temperature	-40 to +70°C
Beam Angle	45°
CRI	85
Weight	6.8kg
Body / Finish Color	Aluminium

### Warning:

- \* Do not look permanently to the light sources
- \* Specified performance measured in AC 110-260V

